



「Beakerlite NEO」 sample jar for aviation fuel testing

The “ultra” weight -saving of liquid sample inspection equipment will improve workability greatly during inspection!

Registered in December 13,2022/
Holding mechanism and container unit
(Aviation fuel quality control container)

Patented No.7194244

Background

Many of the sample jars we use have glass handles. The base of the sample jar handle is often damaged since too much force by shock is applied while in use. To enhance durability, we had to select sturdy beakers, which inevitably forced us to use heavy one. It also may not be suitable for work in limited spaces due to its size.

Regarding the lid, there was a concern that foreign objects like dust and dirt would be attached because the lid was removed and placed on the ground when fuel was put in and out. It was necessary to reduce the adhesion of foreign objects as it affects quality control.

Overview

- Lightweight stainless frame with handle, which can be impact protection on the ground, was developed and succeeded in weight saving for the container.
- Rubber cushion and rubber leg between container holder and glass container keeps glass container float so that it won't get shock directly.
- By adopting a hinge system, there is no need to place the lid on the ground during work, which saves space and allows to work with speed. The lid can be temporarily held opening at approximately 120° and 170°.
- The internal pressure is released and the container is sealed by pressing the operation knob when closing the lid.
- Adopted SEISHO Co., Ltd., a Japanese glass manufacturer, for the glass container
- As the glass container is fixed by a stainless steel band ,user can replace it easily.

Specifications

Item	Specifications
Name	“ Beakerlite NEO” sample jar for aviation fuel testing
Capacity	1,300ml (Made by SEISHO Co.Ltd)
Weight	755g
Dimensions	Dimensions (Outer): 175×113.5×197mm

outline drawing

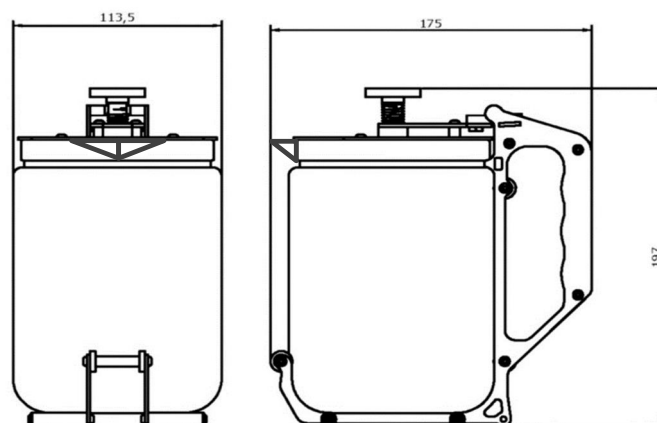

Sample jar for aviation fuel testing

Beakerlite NEO

Maintenance and
Inspections · Quality
Control Tools

Ultra-Lightweight

Compact size

Affordable



Beakerlite NEO



1.

Compact size, Lightweight design, Portable, Easy to work in limited spaces



2.

Protect the container wall from shock by floating



3.

Nylon cushioning material to absorb the shock from bottom



4.

With hinged lid, no need to remove the lid and place on ground



5.

Equipped with pressure releasing valve to prevent the lid from lifting



6.

The glass container is fixed by a stainless steel band and easily replaced. Made by SEISHO Co., Ltd., a Japanese glass manufacturer providing affordable and high quality glass.

